

GTC-600

60 TON MAX. LIFTING CAPACITY

EUROMOT 4

**TELESCOPIC
BOOM
CRAWLER
CRANE**



GENERAL DATA

CRANE CAPACITY	60 t at 3.0 m
BOOM	4-section, 11.5 m – 36.0 m
DIMENSION	
Overall Length	14.03 m
Overall Width (tracks extended)	4.92 m
Overall Width (tracks retracted)	3.27 m
Overall Height (working)	3.89 m
MASS	
Gross Vehicle Mass (Standard Crane)	60784 kg
Maximum Counterweight	Upper = 13608 kg Carbody = 6000 kg
PERFORMANCE	
Travel Speed	1.3 km/h / 3.8 km/h
Gradeability	78 %

CRANE SPECIFICATION

MODEL	CAPACITY
GTC-600	60 t at 3.0 m

BOOM

4-section full power telescoping boom with 2 extension modes. System consists of two double acting cylinders with load holding valves and extension and retraction cables.

- Retracted Length: 11.5 m
- Extended Length: 36.0 m
- Elevating Angles: -1.5° to 80.0°
- Max. Lifting Height: 36.1 m
- Boom Head: Five, 495 mm diameter cast nylon main sheaves on heavy-duty roller bearings. Two, 445 mm diameter cast nylon lead in sheaves on heavy-duty roller bearings. Designed for quick reeving of head and load block.
- Extension Time: 118 s
- Elevating Time: 83 s

AUXILIARY BOOM HEAD

Quick reeve, single 445 mm diameter high-strength, steel sheave mounted on a heavy-duty roller bearing. Allows single part reeving.

COUNTERWEIGHT

4 piece counterweight design. Two upper counterweight configurations

- “A” Configuration = 6804 kg
- “B” Configuration = 13608 kg
- Two carbody counterweights, 3000 kg each

WINCHES

Planetary geared two-speed winch includes a hydraulic motor, multi-disc internal brake and counterbalance valve. Drum rotation indicator is included (complete winch performance specs on Page 4).

- Main Winch
 - o Rope Diameter and Length: 19 mm x 198 m
 - o Single line pull: 88.2 kN (first layer)
 - o Single line speed: 112.2 m/min (4th layer)

TRAVEL

Each side frame contains a pilot controlled, two-speed track drive with hydraulic axial piston motor and parking brake. Travel system provides skid steering and counter rotation.

- travel speed - Low: 1.3 km/h High: 3.8 km/h
- Gradeability (unladen): 78 %
- Unladen Ground Pressure: 6.7 t/m²

SWING

Gear motor driving a planetary gear reducer with a shaft mounted pinion, external gear shear ball slew bearing bolted to the superstructure and the carbody allows the superstructure to rotate 360°.

- Swing Speed: 0 - 2.2 rpm
- Swing Parking Brake: Spring applied failsafe brake with hydraulic release that is controlled from the operators cab
- Swing Service Brake: Hydraulically applied, controlled through foot actuated pedal
- House Lock System
 - o 4-position house lock (boom over front, rear or either side). Actuated from the operator’s cab.

LOAD MOMENT INDICATOR

TADANO AML-C Rated Capacity Limiter and Anti-Two Block system

- OPTI-WIDTH™ - OPTIMAL lifting performance at any track WIDTH
- Control function shutdown. Audible and visual warnings
- LCD screen provides a continuous display of working boom length, boom angle, working load radius, tip height, swing position, parts-of-line (operator set), machine track configuration, relative load moment, maximum permissible load and actual load.
- Anti-two block weight allows quick reeving of hook block.
- Operator configurable working range limits with automatic soft stop

FRAME

The frame is an all-steel, welded structure, precision machined to accept attachment of the boom and swing components.



OPERATORS CAB

Fully-enclosed, air conditioned all-steel modular cab with lockable sliding door, acoustical lining, anti-slip floor and tinted safety glass

- Cab tilts 20°
- Rear view, winch view and right side view video cameras
- Three remote control work lights
- Vent window in the rear of the cab
- Grab bars and steps are located for easy access to the cab.
- Defroster, heater, circulating fan
- Emergency stop button
- 2-speed windshield wiper, top glass wiper
- Six-way adjustable fabric seat with headrest, seat belt
- Dome light
- Dry-chemical fire extinguisher
- Four-way electronic armrest mounted joysticks control swing, main winch, auxiliary winch, boom hoist and boom extend. Foot pedals control the travel and swing service brake functions. Swing brake pedal is hydraulic.
- Selectable modes for Fine Control and Travel. Travel function can be operated by foot pedals or joystick.
- Seat termination switch immediately disable all hydraulic functions as the operator rises from the seat. Functions can also be disabled by switch on console.
- Dash instrumentation: tachometer, hour meter, fuel gauge, and DEF level gauge. Indicators are provided for crane level, swing position, load moment, drum rotation, air filter restriction, engine oil temperature and pressure, hydraulic oil temperature and level, and hydraulic and air filter restriction, and low voltage.

ENGINE

- Make/Model: Cummins QSB6.7
- Type: 6 Cylinder, Water cooled, 4 Cycle
- Aspiration: Turbocharged and Aftercooled
- Max. Output: 231 kW @ 2200 rpm
- Max Torque: 1044 Nm @ 1500 rpm
- Piston Disp: 6.7 l
- Emission Cert: Euromot Stage IV
- Alternator: 70 A

ELECTRICAL SYSTEM

24 V DC

FUEL SYSTEM

- Capacity: 321 l
- Filtration: Inline fuel/water separator and engine mounted fuel filter

SIDE FRAMES

Two welded steel side frames are paired with a track group. The side frames extend and retract hydraulically and are controlled from the cab.

- Track Rollers: Two top and thirteen bottom sealed rollers on each track frame
Idler: Oil filled, self lubricating with spring type tensioner
- Track Shoes: 900 mm, 3-bar semi grouser

HYDRAULIC SYSTEM

- Hydraulic Pumps: Two high pressure, variable axial piston pumps with load sense and power limiting control for crane functions. One axial piston pump for swing function. One gear pump for cooling loop
- Directional Valves: Multiple pressure and flow compensated valves with integrated relief valves controlled by electrical signals.
- Pump output: 582 l/min @ 2200 rpm engine speed. 345 bar maximum pressure
- Reservoir: 861 liter capacity, spin-on filler/ breather, sight gauge, cleanout, and sump drain
- Filtration: Three 5 micron, full flow tank mounted return filters with electrical clogging indicator. 3 micron pilot oil in-line pressure filter
- Diagnostic Ports: Provided for system, load sense, and pilot pressure

OPTIONAL EQUIPMENT

- Jibs
 - o Main jib
 - Total Length: 10.1 m
 - Max. Lifting Height: 46.3 m
 - Offset Angles: 3.5°, 25° & 45°
 - o Fly jib
 - Total Length: 17.7 m
 - Max. Lifting Height: 53.7 m
 - Offset Angles: 3.5°, 25° & 45°
 - o Heavy lift jib
 - Total Length: 2.5 m
 - Max. Lifting Height: 38.6 m
 - Offset Angles: 3.5° & 30°
- Auxiliary Winch
 - o Rope Diameter and Length: 19 mm x 125 m
 - o Single line pull: 88.2 kN (first layer)
 - o Single line speed: 112.2 m/min (4th layer)
- Hook blocks
 - o 60 t quick reeve hook block – five, 495 mm steel sheaves, swivel hook and safety latch
 - o 50 t quick reeve hook block – three, 495 mm steel sheaves, swivel hook and safety latch
 - o 20 t quick reeve hook block – one, 495 mm steel sheave, swivel hook and safety latch
- Overhaul ball – 8 t with swivel hook & safety latch
- 360 degree house lock. Actuated from the operator's cab.
- Track Shoes:
 - o Flat shoes in 800 mm or 900 mm width
 - o 3-bar semi grousers in 800mm or 600mm width

GTC-600

- Auger: Hydraulic auger boom package includes auger motor, hoses, fasteners, and stowage bracket assembly mounted to the 2nd stage section of boom for variable radius drilling.
- Tool Circuit: Provides 23 l/min and 45 l/min at 176 bar through a 15.2 m twin hose reel with quick disconnect fittings to operate open center tools.
- High Flow Tool Circuit: Provides 170 l/min at 330 bar.
- Cold Weather Packages: Cold weather options are available for operation to -40 °C (Consult factory for application support).
- Radio control package (available in approved markets only)
- Anemometer: boom mounted wireless anemometer with cab display.
- Central lubrication system

MAIN WINCH AND AUXILIARY WINCH PERFORMANCE

Wire Rope: 19 mm diameter rotation resistant. Line pulls are not based on wire rope strength.

Rope Layer	Maximum Line Pull (kN)	High Line Speed (m/min)	Normal Line Speed (m/min)	Pitch Diameter (mm)	Layer (m)	Total (m)
1	88.2	88.5	52.6	381	34.2	34.2
2	79.9	96.4	57.3	421.6	37.3	71.5
3	73	104.3	62.1	462.3	40.3	111.8
4	67.2	112.2	66.8	500.1	43.4	155.2
5	62.3	120.9	71.5	541	46.4	201.5
6	58	128.1	76.2	581.7	49.5	251

MACHINE WEIGHTS

kg

Standard Crane with 4 section - 36 m boom, full counterweight, 1 winch with wire rope and 900 mm 3-bar semi grouser track shoes

60784

Standard Crane with with 4 section - 36 m boom, 1 winch with wire rope and 900 mm 3-bar semi grouser track shoes (counterweight removed)

41176

OPTIONAL EQUIPMENT

kg

Heavy Lift Jib (2.5 m)

441

Jib Base (10.1 m)

919

Jib Tip (7.5 m)

339

Auxiliary Nose Sheave

48

60 t hook block - five sheave

510

50 t hook block - three sheave

640

20 t hook block - one sheave

300

8 t Overhaul Ball

140

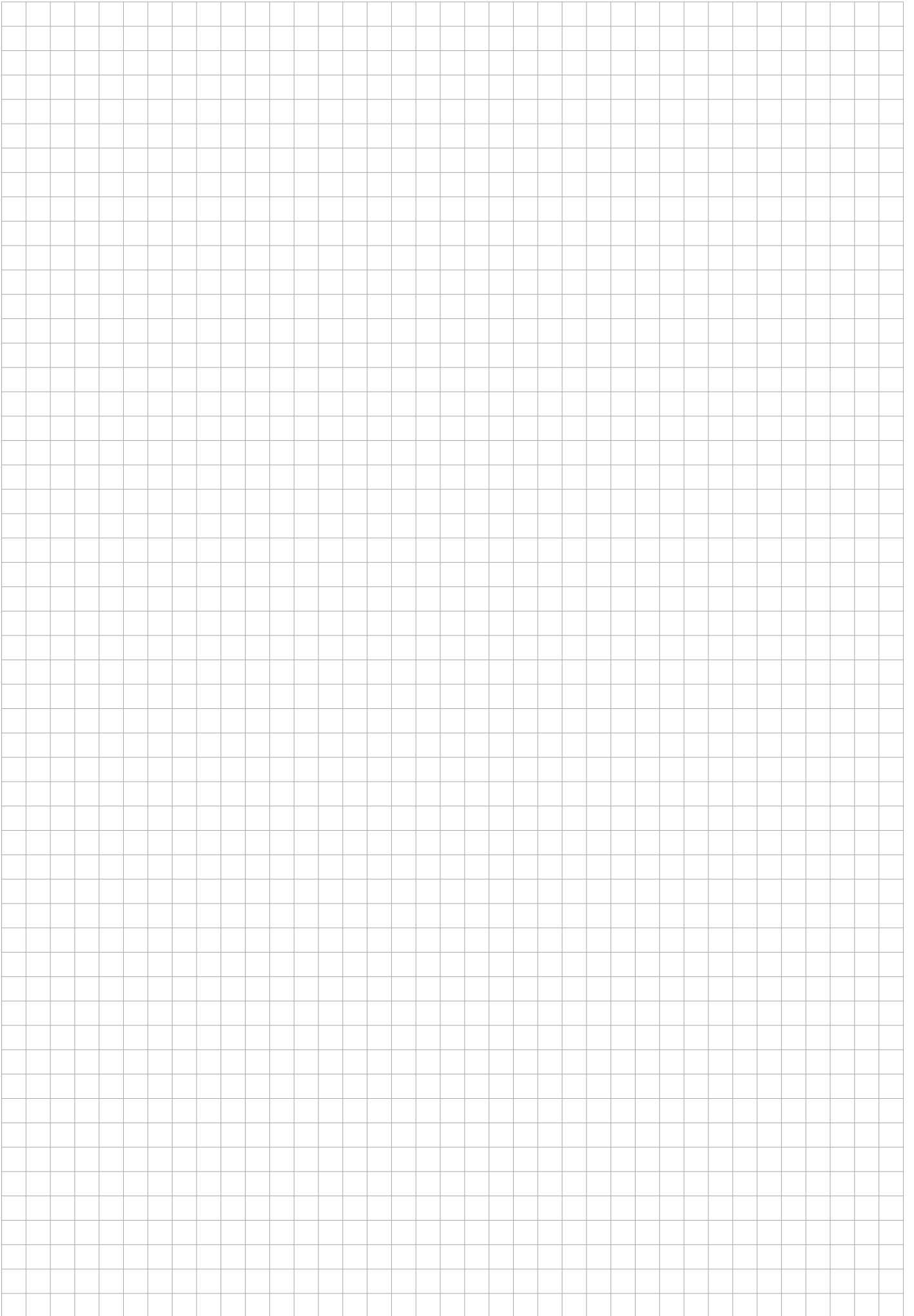

GTC-600

DIMENSIONS

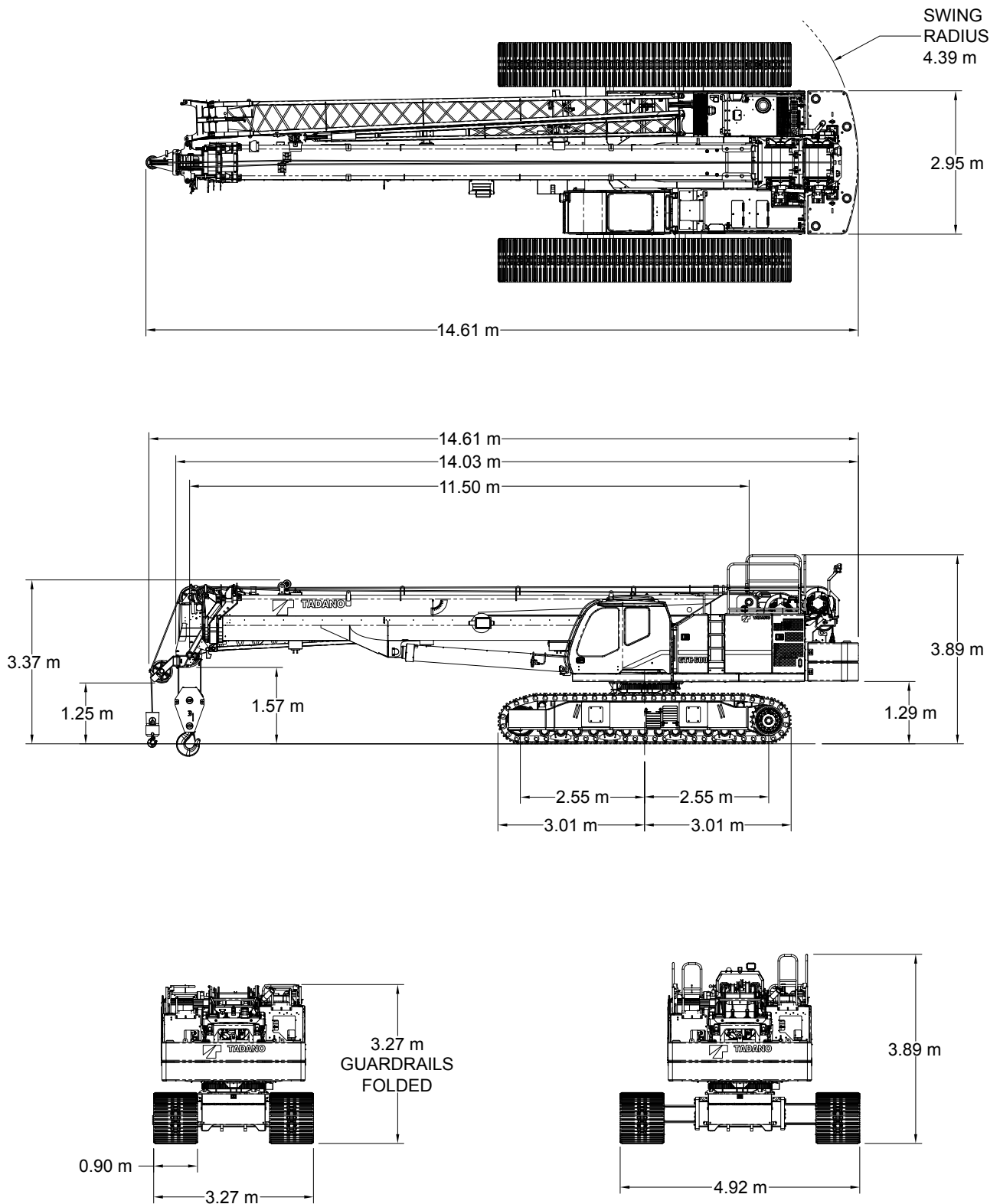

TRANSPORT

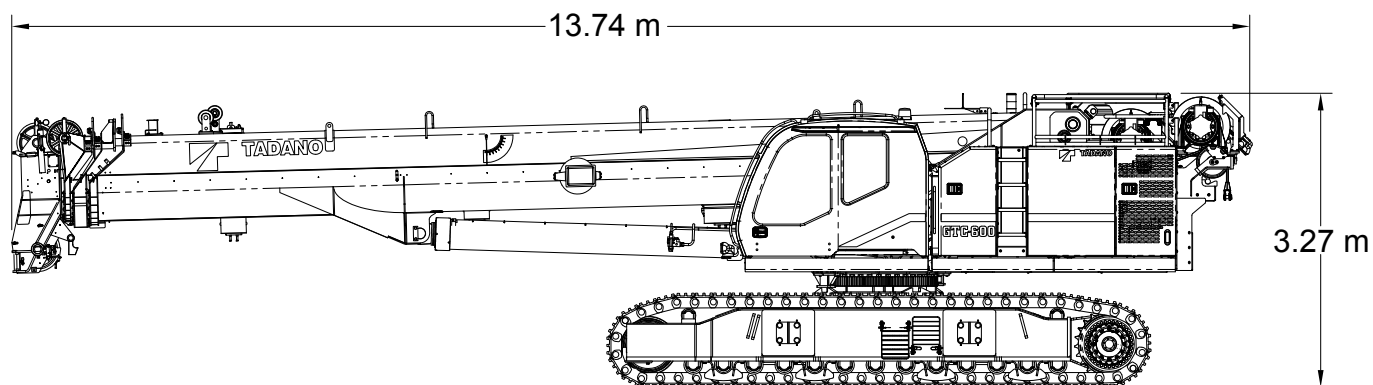

Item	Weight	Dims (L x W x H)	Trailer	
	kg		1	2
Crane (with 2 winches, Boom, wire rope, aux nose sheave)	42026	13.74 m x 3.27 m x 3.27 m	x	
Counterweight A	6804	2.95 m x 1.11 m x 1.04 m		x
Counterweight B - 1 piece	6804	2.95 m x 0.47 m x 1.04 m		x
Counterweight - Carbody - 1 piece	3000	1.30 m x 1.25 m x 0.73 m		x
Counterweight - Carbody - 1 piece	3000	1.30 m x 1.44 m x 0.76 m		x
Jib base section	919	10.55 m x 1.47 m x 0.91 m	x	
Jib point	339	7.84 m x 0.73 m x 0.74 m	x	
Hook Block - 60 t	510	1.57 m x 0.61 m x 0.46 m	x	
Headache Ball - 8 t	140	0.74 m x 0.28 m x 0.28 m	x	
Miscellaneous Items (Crate)	23	1.22 m x 0.91 m x 0.91 m	x	
Total Net Weight on Trailer (kg)			43957	19608

GTC-600

TRANSPORT

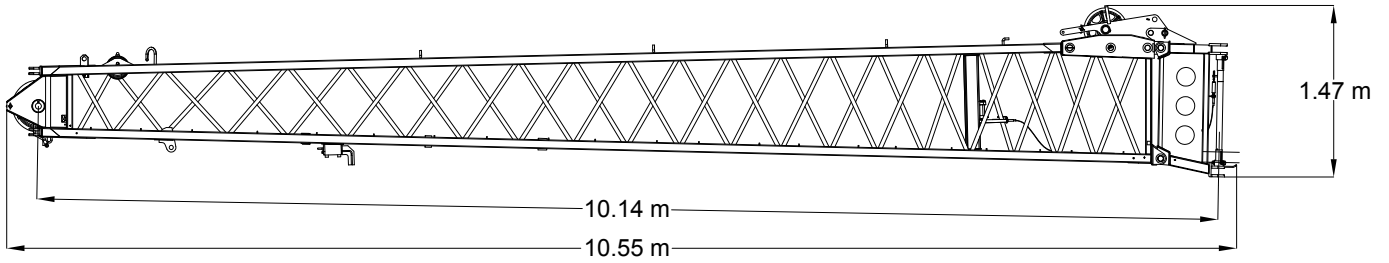

10.1 m EXTENSION
WEIGHT: 919 kg

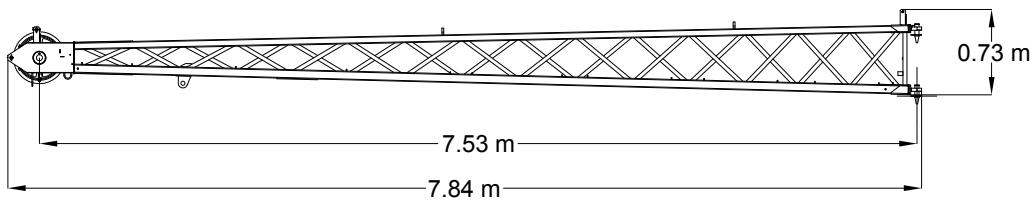

7.5 m JIB POINT
WEIGHT: 339 kg

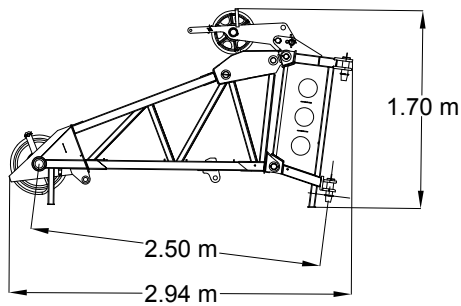

2.5 m HEAVY LIFT JIB
WEIGHT: 441 kg

TRANSPORT

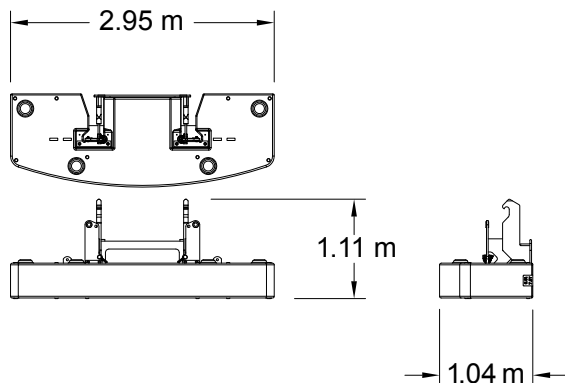

CONFIGURATION "A"
WEIGHT: 6804 kg

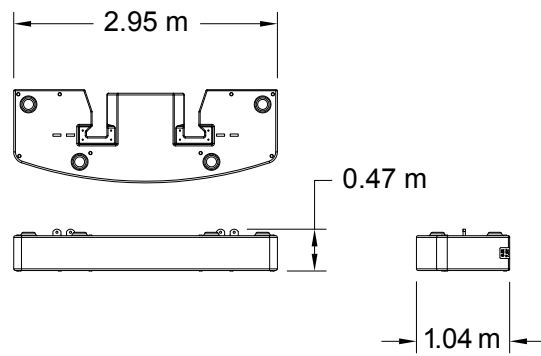

CWT "B" SECTION
WEIGHT: 6804 kg

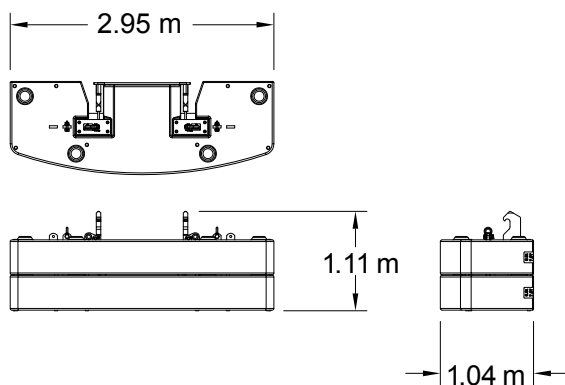

CONFIGURATION "B"
WEIGHT: 13608 kg

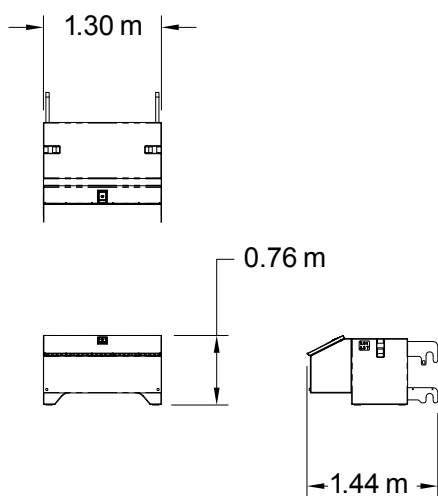

REAR CARBODY CWT
WEIGHT: 3000 kg

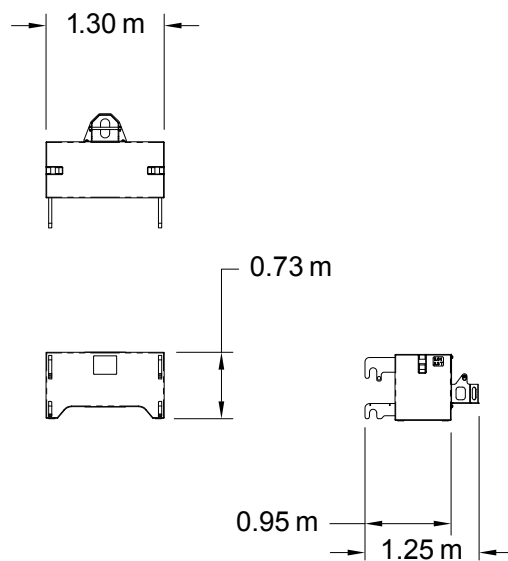

FRONT CARBODY CWT
WEIGHT: 3000 kg

WORKING RANGE - HEAVY LIFT JIB

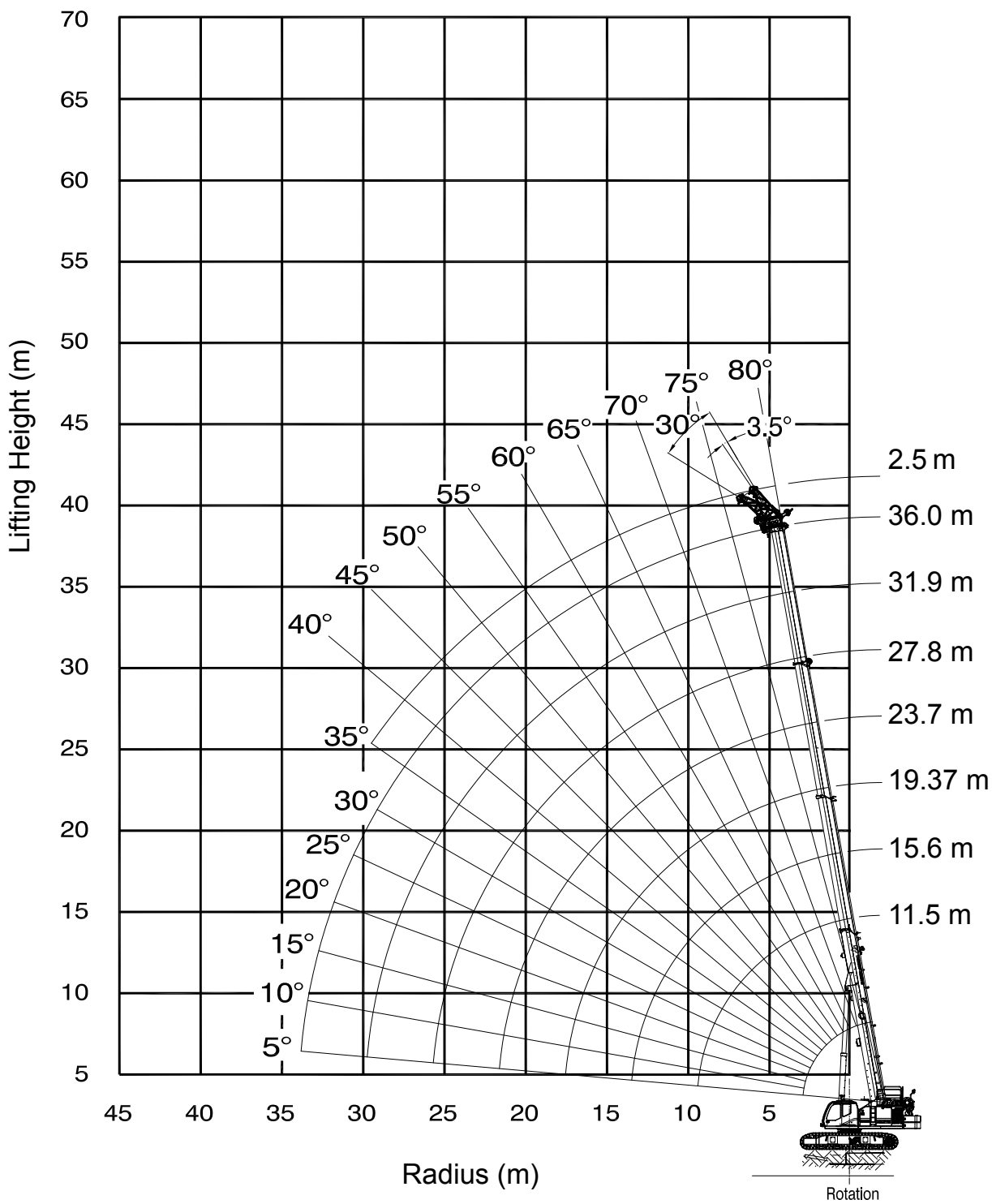

WORKING RANGE - JIB

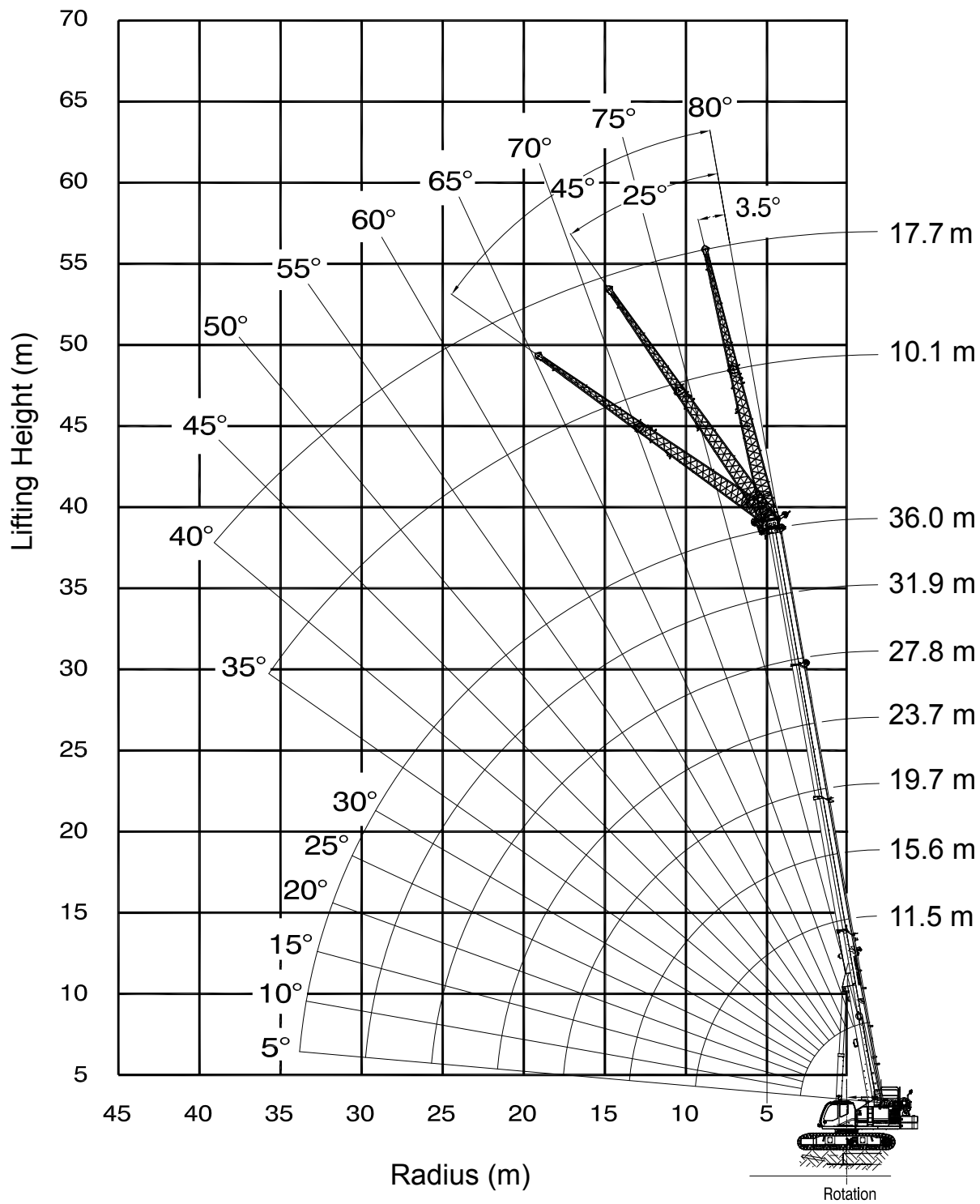

LOAD CHARTS

MAIN BOOM WITH TRACKS FULLY EXTENDED - 360° UP TO 1.5° SLOPE - NO TRAVEL								
13.6 t MAIN COUNTERWEIGHT AND 6.0 t CARBODY COUNTERWEIGHT								
Radius (m)	MAIN BOOM LENGTH (m)							Radius (m)
	11.5	15.6	19.7	23.8	27.8	31.9	36.0	
3	60.0	52.4	45.8					3
4	50.4	49.8	34.9	16.9	16.5			4
5	39.9	38.2	34.1	16.9	16.4	15.7		5
6	32.7	30.7	27.7	16.9	16.4	15.7	13.5	6
7	27.0	25.5	23.1	16.9	16.4	15.6	13.5	7
8	22.1	21.0	19.7	16.9	16.4	15.5	12.9	8
9	18.7	17.6	16.9	16.6	16.1	15.4	12.0	9
10		16.2	16.2	14.6	14.2	13.8	11.2	10
12		12.5	12.5	12.3	11.3	11.2	9.8	12
14			10.0	10.1	9.0	9.1	8.7	14
16			8.3	8.3	7.2	7.3	7.5	16
18				7.0	5.9	6.5	6.2	18
20				6.0	5.2	5.6	5.2	20
22					4.7	4.8	4.4	22
24					4.3	4.1	3.7	24
26						3.5	3.2	26
28						3.0	2.7	28
30							2.3	30
32							2.0	32
PARTS OF LINE	10	8	8	4	4	4	2	PARTS OF LINE

LOAD CHARTS

MAIN BOOM WITH TRACKS FULLY EXTENDED - 360° UP TO 4° SLOPE - NO TRAVEL								
13.6 t MAIN COUNTERWEIGHT AND 6.0 t CARBODY COUNTERWEIGHT								
Radius (m)	MAIN BOOM LENGTH (m)							Radius (m)
	11.5	15.6	19.7	23.8	27.8	31.9	36.0	
3	59.1	43.5	34.9					3
4	47.6	39.3	33.4	16.9	16.5			4
5	37.3	31.4	27.2	16.9	16.4	14.3		5
6	29.7	26.0	22.8	16.9	16.4	14.3	11.5	6
7	24.1	21.8	19.4	16.9	16.4	14.3	11.5	7
8	20.2	18.2	16.8	15.9	15.1	14.3	11.4	8
9	17.5	16.7	16.2	14.1	13.4	12.7	10.7	9
10		14.6	14.2	13.1	12.0	11.5	10.0	10
12		11.6	11.2	10.9	9.6	9.4	8.9	12
14			9.2	9.0	7.7	7.6	7.7	14
16			7.7	7.5	6.3	6.7	6.3	16
18				6.4	5.5	5.8	5.3	18
20				5.6	5.0	4.9	4.5	20
22					4.6	4.2	3.8	22
24					4.2	3.7	3.3	24
26						3.2	2.8	26
28						2.8	2.4	28
30							2.0	30
32							1.8	32
PARTS OF LINE	10	4	4	4	2	2	2	PARTS OF LINE

LOAD CHARTS

MAIN BOOM WITH TRACKS RETRACTED - OVER FRONT/REAR UP TO 1.5° SLOPE - NO TRAVEL								
13.6 t MAIN COUNTERWEIGHT AND 6.0 t CARBODY COUNTERWEIGHT								
Radius (m)	MAIN BOOM LENGTH (m)							Radius (m)
	11.5	15.6	19.7	23.8	27.8	31.9	36.0	
3	60.0	52.4	45.8					3
4	50.4	50.0	34.9	16.9	16.5			4
5	39.9	39.5	34.2	16.9	16.4	15.7		5
6	32.7	32.4	30.9	16.9	16.4	15.7	13.5	6
7	27.6	27.2	26.9	16.9	16.4	15.6	13.5	7
8	23.7	23.3	23.0	16.9	16.4	15.5	12.9	8
9	20.6	20.2	19.9	16.9	16.4	15.4	12.0	9
10		17.8	17.5	16.9	15.7	14.3	11.2	10
12		15.1	15.1	13.7	13.5	12.3	9.8	12
14			12.1	11.0	10.9	10.7	8.7	14
16			10.0	10.0	8.9	9.0	7.8	16
18				8.4	7.3	7.5	7.1	18
20				7.2	6.1	6.3	6.4	20
22					5.2	5.3	5.5	22
24					4.4	4.9	4.7	24
26						4.4	4.1	26
28						3.9	3.5	28
30							3.1	30
32							2.7	32
PARTS OF LINE	10	8	8	4	4	4	2	PARTS OF LINE

LOAD CHARTS

MAIN BOOM WITH TRACKS FULLY RETRACTED - OVER SIDE UP TO 1.5° SLOPE - NO TRAVEL								
13.6 t MAIN COUNTERWEIGHT AND 6.0 t CARBODY COUNTERWEIGHT								
Radius (m)	MAIN BOOM LENGTH (m)							Radius (m)
	11.5	15.6	19.7	23.8	27.8	31.9	36.0	
3	*	*	*					3
4	*	*	*	*	*			4
5	*	*	*	*	*	*		5
6	20.4	*	*	*	*	*	*	6
7	16.5	15.6	*	*	*	*	*	7
8	13.6	14.0	13.8	*	*	*	*	8
9	11.5	11.8	11.9	11.7	*	10.3	9.5	9
10		10.2	10.3	10.3	9.7	9.2	8.4	10
12		7.8	7.9	8.0	8.1	7.4	6.7	12
14			6.3	6.4	6.5	6.0	5.5	14
16			5.1	5.2	5.3	4.9	4.5	16
18				4.3	4.4	4.0	3.6	18
20				3.6	3.6	3.2	2.9	20
22					3.1	2.7	2.3	22
24					2.6	2.2	1.9	24
26						1.8	1.5	26
28						1.5	1.1	28
30							0.8	30
32							0.6	32
PARTS OF LINE	10	8	8	4	4	4	2	PARTS OF LINE

LOAD CHARTS

MAIN BOOM WITH TRACKS FULLY EXTENDED - 360° UP TO 1.5° SLOPE - NO TRAVEL								
0 t MAIN COUNTERWEIGHT AND 6.0 t CARBODY COUNTERWEIGHT								
Radius (m)	MAIN BOOM LENGTH (m)							Radius (m)
	11.5	15.6	19.7	23.8	27.8	31.9	36.0	
3	48.8	39.4	32.9					3
4	32.6	27.4	23.6	16.9	16.5			4
5	24.0	20.6	18.0	16.9	16.0	15.0		5
6	18.7	16.9	16.4	15.4	13.0	13.1	11.8	6
7	14.4	14.4	13.7	12.9	11.3	11.1	10.0	7
8	11.5	11.9	11.6	11.0	10.6	9.5	8.6	8
9	9.5	9.8	9.9	9.6	9.2	8.2	7.4	9
10		8.3	8.4	8.3	8.1	7.2	6.5	10
12		6.1	6.2	6.3	6.3	5.6	5.0	12
14			4.7	4.8	5.0	4.4	3.9	14
16			3.7	3.8	3.9	3.5	3.0	16
18				3.0	3.1	2.7	2.4	18
20				2.4	2.5	2.1	1.8	20
22					2.0	1.6	1.3	22
24					1.6	1.2	0.9	24
26						0.8	*	26
28						0.6	*	28
30							*	30
32							*	32
PARTS OF LINE	10	8	8	4	4	4	2	PARTS OF LINE

LOAD CHARTS

AUX NOSE SHEAVE WITH TRACKS FULLY EXTENDED - 360° UP TO 1.5° SLOPE - NO TRAVEL								
13.6 t MAIN COUNTERWEIGHT AND 6.0 t CARBODY COUNTERWEIGHT								
Radius (m)	MAIN BOOM LENGTH (m)							Radius (m)
	11.5	15.6	19.7	23.8	27.8	31.9	36.0	
3	6.6	6.6	6.6					3
4	6.6	6.6	6.6	6.6				4
5	6.6	6.6	6.6	6.6	6.6			5
6	6.6	6.6	6.6	6.6	6.6	6.6	6.6	6
7	6.6	6.6	6.6	6.6	6.6	6.6	6.6	7
8	6.6	6.6	6.6	6.6	6.6	6.6	6.6	8
9	6.6	6.6	6.6	6.6	6.6	6.6	6.6	9
10	6.6	6.6	6.6	6.6	6.6	6.6	6.6	10
12		6.6	6.6	6.6	6.6	6.6	6.6	12
14		6.6	6.6	6.6	6.6	6.6	6.6	14
16			6.6	6.6	6.6	6.6	6.6	16
18			6.6	6.6	6.1	6.3	6.4	18
20				6.1	5.1	5.3	5.4	20
22				5.3	4.3	4.9	4.5	22
24					3.9	4.2	3.9	24
26					3.6	3.6	3.3	26
28						3.1	2.8	28
30						2.7	2.4	30
32							2.0	32
34							1.7	34
PARTS OF LINE	1	1	1	1	1	1	1	PARTS OF LINE

GTC-600

LOAD CHARTS

2.5 m JIB WITH TRACKS EXTENDED - 360° UP TO 1.5° SLOPE - NO TRAVEL											
13.6 t MAIN COUNTERWEIGHT AND 6.0 t CARBODY COUNTERWEIGHT											
Radius (m)	MAIN BOOM LENGTH (m)										Radius (m)
	11.5		23.8		27.8		31.9		36.0		
	3.5°	30°	3.5°	30°	3.5°	30°	3.5°	30°	3.5°	30°	
3	20.4	15.9									3
4	19.1	15.3	15.1								4
5	18.1	14.9	12.5	15.0	12.5						5
6	17.3	14.5	12.4	12.2	11.0	12.0	12.9				6
7	16.6	14.3	12.3	12.1	10.7	10.4	11.7	11.3	12.1		7
8	16.0	14.1	12.2	12.0	10.1	9.9	10.7	10.4	11.1	10.7	8
9	15.6	14.1	12.1	11.9	9.2	9.0	9.9	9.6	10.3	9.9	9
10	15.4	14.1	12.1	11.9	8.5	8.3	9.1	8.9	9.6	9.2	10
12			11.0	10.7	7.2	7.1	7.9	7.7	8.4	8.1	12
14			9.8	9.6	6.3	6.2	6.9	6.8	7.4	7.2	14
16			8.1	8.2	5.5	5.5	6.1	6.0	6.6	6.5	16
18			6.8	6.8	4.9	4.9	5.5	5.4	5.9	5.8	18
20			5.7	5.8	4.4	4.3	4.9	4.9	4.9	5.0	20
22			4.9		3.9	3.9	4.4	4.4	4.1	4.2	22
24			4.2		3.5	3.5	3.8	3.8	3.4	3.5	24
26					3.2		3.2	3.2	2.9	2.9	26
28					3.0		2.7	2.7	2.4	2.4	28
30							2.3		2.0	2.0	30
32							2.0		1.6	1.6	32
34									1.3		34
36									1.1		36
PARTS OF LINE	4	4	2	2	2	2	2	2	2	2	PARTS OF LINE

LOAD CHARTS

10.1 m JIB WITH TRACKS FULLY EXTENDED - 360° UP TO 1.5° SLOPE - NO TRAVEL																
13.6 t MAIN COUNTERWEIGHT AND 6.0 t CARBODY COUNTERWEIGHT																
Radius (m)	MAIN BOOM LENGTH (m)															Radius (m)
	11.5			23.8			27.8			31.9			36.0			
	3.5°	25°	45°	3.5°	25°	45°	3.5°	25°	45°	3.5°	25°	45°	3.5°	25°	45°	
3	6.6															3
4	6.6															4
5	6.6															5
6	6.6			6.6												6
7	6.6	6.6		6.6			6.6			6.6						7
8	6.6	6.6		6.6			6.6			6.6			6.0			8
9	6.6	6.4	5.4	6.6	6.6		6.6			6.6			6.0			9
10	6.6	6.1	5.2	6.6	6.6		6.6	6.5		6.6			6.0			10
12	6.6	5.5	4.8	6.6	6.3	5.1	6.4	6.1		6.6	6.3		6.0	6.4		12
14	6.0	5.1	4.6	6.6	5.9	4.9	6.0	5.8	4.9	6.3	5.9	5.0	6.0	5.8		14
16	5.4	4.8	4.5	6.6	5.5	4.7	5.4	5.2	4.7	5.6	5.3	4.8	5.7	5.3	4.8	16
18	5.0	4.5	*	6.3	5.2	4.5	4.8	4.7	4.6	5.0	4.8	4.6	5.2	4.9	4.7	18
20				5.8	5.0	4.4	4.3	4.2	4.2	4.6	4.4	4.3	4.7	4.5	4.3	20
22				5.4	4.8	4.3	3.9	3.8	3.8	4.2	4.0	4.0	4.3	4.1	4.0	22
24				4.7	4.6	4.3	3.6	3.5	3.5	3.8	3.7	3.7	3.9	3.8	3.7	24
26				4.1	4.3	4.3	3.3	3.2	3.2	3.5	3.4	3.4	3.3	3.6	3.5	26
28				3.6	3.8	*	3.0	3.0	3.0	3.2	3.2	3.2	2.8	3.1	3.3	28
30				3.2	3.3		2.8	2.7	*	2.8	2.9	3.0	2.4	2.7	2.8	30
32				2.9			2.6	2.6		2.4	2.6	2.6	2.1	2.3	2.4	32
34							2.4	2.4		2.1	2.2	*	1.8	1.9	2.0	34
36							2.2			1.8	1.9		1.5	1.6	*	36
38										1.6	1.6		1.2	1.3		38
40										1.4			1.0	1.1		40
PARTS OF LINE	1	1	1	1	1	1	1	1	1	1	1	1	1	1	1	PARTS OF LINE

LOAD CHARTS

17.1 m JIB WITH TRACKS FULLY EXTENDED - 360° UP TO 1.5° SLOPE - NO TRAVEL																
13.6 t MAIN COUNTERWEIGHT AND 6.0 t CARBODY COUNTERWEIGHT																
Radius (m)	MAIN BOOM LENGTH (m)															Radius (m)
	11.5			23.8			27.8			31.9			36.0			
	3.5°	25°	45°	3.5°	25°	45°	3.5°	25°	45°	3.5°	25°	45°	3.5°	25°	45°	
5	4.5															5
6	4.5															6
7	4.5															7
8	4.5			3.7												8
9	4.5			3.7			3.5									9
10	4.5			3.7			3.5			3.3						10
12	4.0	3.6		3.7			3.5			3.3			3.2			12
14	3.6	3.3		3.7	3.6		3.5			3.3			3.2			14
16	3.2	3.1	2.6	3.7	3.4		3.5	3.4		3.3	3.3		3.2			16
18	3.0	2.8	2.5	3.6	3.2	2.6	3.5	3.2		3.3	3.3		3.2	3.2		18
20	2.7	2.6	2.3	3.3	3.0	2.5	3.4	3.1	2.5	3.3	3.1	2.5	3.2	3.1		20
22	2.5	2.4	2.2	3.1	2.8	2.4	3.2	2.9	2.4	3.3	3.0	2.4	3.2	3.0	2.4	22
24	2.3	2.2	2.1	2.9	2.6	2.3	3.0	2.7	2.3	3.1	2.8	2.3	3.2	2.9	2.3	24
26	2.2	2.1		2.8	2.5	2.2	2.9	2.6	2.2	3.0	2.7	2.2	3.1	2.7	2.3	26
28				2.6	2.4	2.1	2.6	2.5	2.1	2.8	2.5	2.2	2.9	2.6	2.2	28
30				2.5	2.3	2.1	2.4	2.3	2.1	2.6	2.4	2.1	2.6	2.5	2.1	30
32				2.4	2.2	2.0	2.2	2.2	2.0	2.4	2.3	2.0	2.3	2.4	2.1	32
34				2.3	2.1	2.0	2.1	2.1	2.0	2.2	2.2	2.0	2.0	2.3	2.0	34
36				2.2	2.0	*	1.9	1.9	1.9	2.0	2.0	2.0	1.7	2.0	2.0	36
38				2.1	2.0		1.8	1.8	*	1.7	1.9	1.9	1.4	1.7	1.9	38
40							1.6	1.7		1.5	1.7	1.8	1.2	1.4	1.6	40
45										1.0	1.1		0.7	0.9	*	45
50													0.4	0.4		50
PARTS OF LINE	1	1	1	1	1	1	1	1	1	1	1	1	1	1	1	PARTS OF LINE

PLEASE READ, UNDERSTAND, AND FOLLOW THE MANUALS FURNISHED WITH THE CRANE AS WELL AS THE CAPACITY LIMITATIONS AND GENERAL CONDITIONS LISTED BELOW PRIOR TO OPERATION OF THE CRANE. FAILURE TO DO SO MAY RESULT IN AN ACCIDENT.

Performance of this TADANO crane as manufactured by Tadano Mantis Corporation applies only to machines as originally equipped by the manufacturer and in a properly maintained condition. Capacities given are maximum covered by the manufacturer's warranty and are based on a freely suspended load with NO allowance for factors as out-of-level operation (beyond the limits specified on the charts), supporting surface conditions, hazardous surroundings, experience of personnel, etc. The operator shall establish practical working loads based on prevailing operating conditions, such as, but not limited to the above.

* Even without a load, the boom should not be positioned in configurations shown with an * in the load chart to avoid tipping the crane.

The lifting capacities in the structural area are based on DIN 15018 parts 2 and 3 and F.E.M. The lifting capacities in the stability area are based on DIN 15019 part 2 / ISO 4305 / EN 13000.

Maximum admissible wind velocity for working with telescopic boom and jibs is 32 km/h. Consult TADANO for ratings at higher wind speeds.

Side pull on boom is extremely dangerous and must be avoided. DO NOT exceed manufacturer's maximum specified reeving.

Boom angle/boom length relationships given are an approximation of the resulted load radius, which should be an accurate measurement.

Boom height dimensions are measured from ground to center of lower boom head sheave.

It is permissible to attempt to telescope boom with a load within the limits of rated capacities. However, boom angle system hydraulic pressure, and/or boom lubrication may affect operation.

It is permissible to travel with loads within the rated capacity of the crane. Travel speeds should be greatly reduced to reflect terrain limitations and minimize dynamic loads applied to the crane structure.

Lifting capacities are shown in metric tons.

The weight of load handling devices such as hook blocks, slings, etc., must be considered as part of the load and must be deducted from the lifting capacities.

The lifting capacities for the telescopic boom apply to a crane with no jibs or other optional equipment stowed or mounted on the crane.

The working radius is the horizontal distance from the center of rotation to the center of the freely suspended, non-oscillating load.

The lifting capacities are subject to change without prior notice.

The above remarks are for basic information only and the operator's manual must be consulted before operating this crane. All data and performances refer to the standard crane. The addition of optional and other non-standard equipment may affect the performance of the crane.

Load moment indicating and anti-two block systems are operator aids and must never be used in lieu of job site lift planning calculations by the operator which must take into account ground conditions, weather and all other environmental factors prevailing at the time of the lift.

Specifications are subject to change at any time without prior notice. Illustrations and photographs may show optional equipment.

Supersedes all previous issues.

Specifications are subject to change without prior notice.

Load chart data is for reference, load charts supplied in the crane cab shall be used for lift planning.



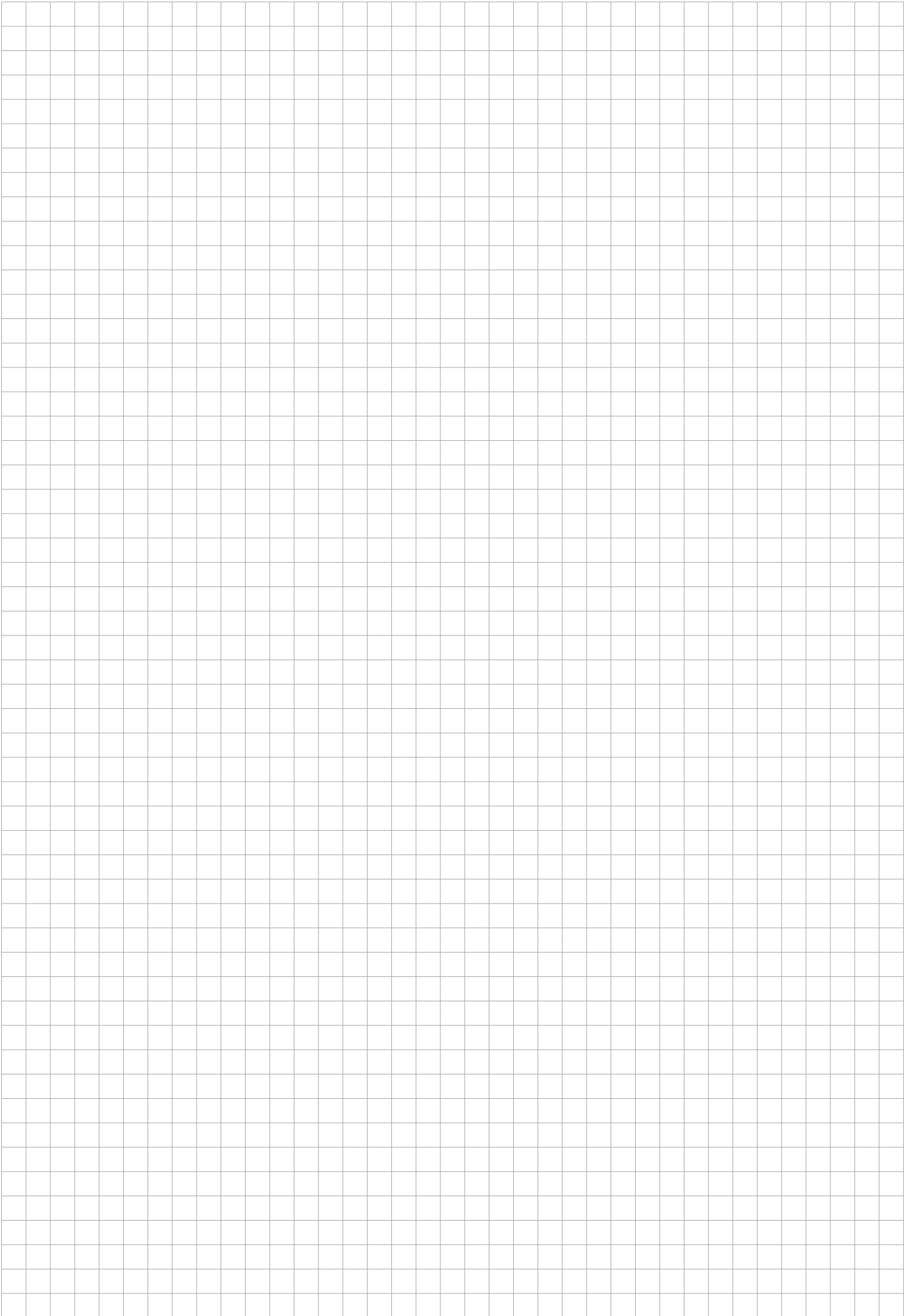



You can find your **direct TADANO contact person** on:
www.tadano.com/wwnetwork/



TADANO FAUN GmbH

Faunberg 2 · 91207 Lauf a. d. Pegnitz · Germany
Phone: +49-9123-185-0 · Fax: +49-9123-3085
www.tadanofaun.de · info@tadanofaun.de

TADANO Mantis Corporation

1705 Columbia Avenue, Suite 200, Franklin, TN 37064 USA
Toll-Free: 1-800-272-3325 · Fax: 615-790-6803
www.mantiscranes.com